



ISO9001 认证

CE

国家高新技术企业

清洁生产

JACK-T373

User Guide

产品使用说明书

 杰克缝纫机
JACK SEWING MACHINE
| [HTTP://WWW.CHINAJACK.COM](http://www.chinajack.com) |

三、按钮机构零件 Button damp mechanism components

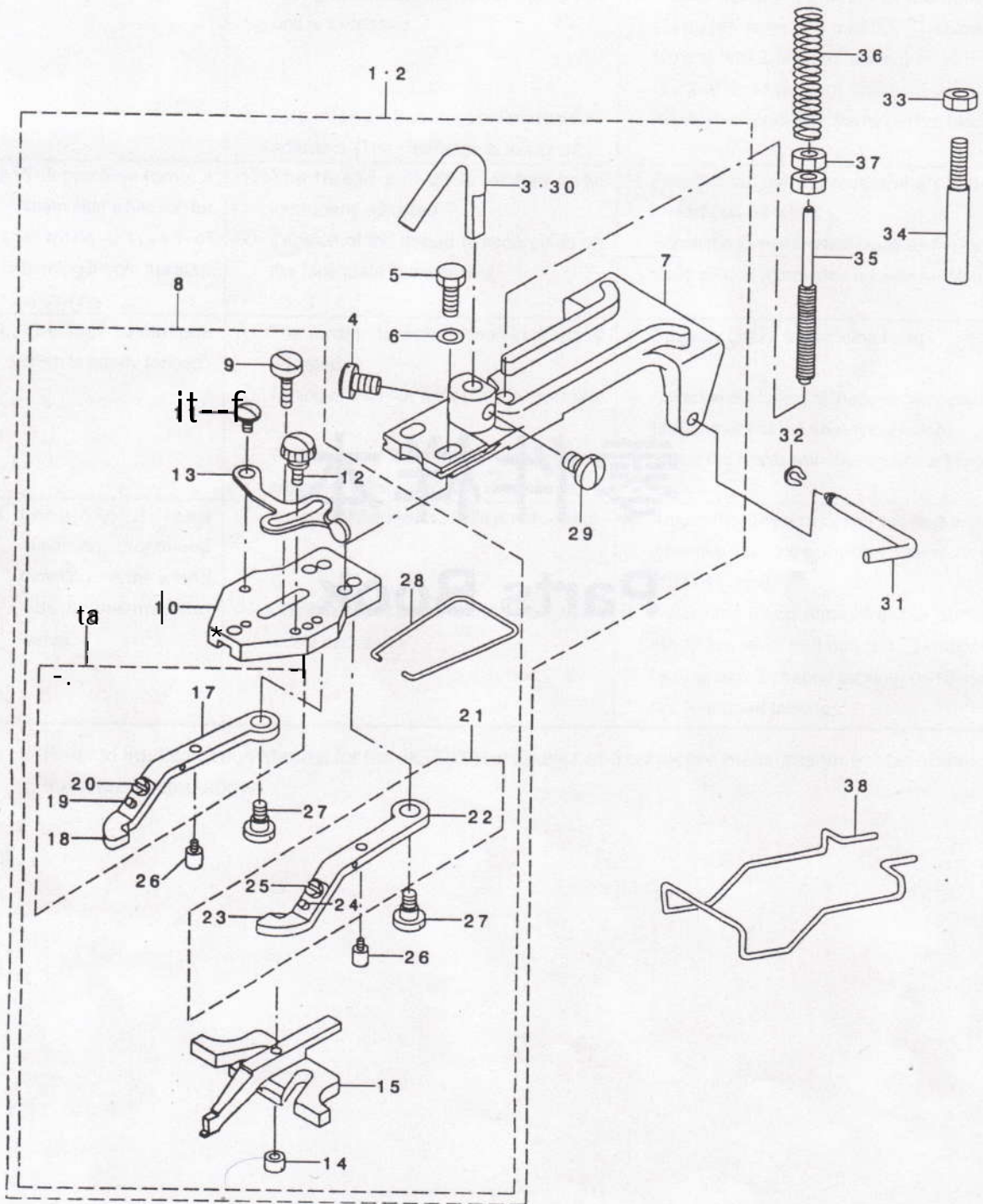

一、钮钳机构部件/Button clamp mechanism components

序号 Ref.no	注解 Note	零件图号 Part.no	名称	Description	数量 Qty
1	#01	B2547-372-0BA	平面钮扣钳组件	Flat button clamp asm.	1
2	#02	B2547-377-0A0	提升组件	Pick-up device asm.	1
3	#01	B2546-372-000	钮钳提升杆	Button clamp lifting rod	(1)
4		SS-7150940-SP	固定提升杆的螺钉	Screw 15/64-28 L=9	(1)
5		SS-9621413-SP	用于钮钳座的螺钉	Screw 3/16-32 L=13.5	(2)
6		WP-0501016-SD	垫圈	Washer 5x10.5x1	(2)
7		B2542-372-00A	钮钳座	Button clamp holder	(1)
8		B2547-372-0C0	钮钳杆座组件	Jaw lever holder asm.	(1)
9		SD-0550301-SP	用于钮钳座的合叶螺钉(A)	Hinge screw D=5.5 H=1.8	(1)
10		B2547-372-000	钮钳杆钳座	Jaw lever holder	(1)
11		SD-0550181-SP	用于钮钳座的合叶螺钉(B)	Hinge screw D=5.5 H=1.8	(1)
12		B2549-372-000	用于止动杆的夹紧螺钉	Clamp screw A	(1)
13		B2548-372-000	钮钳止动杆	Snap fastener clamp stop lever	(1)
14		B2553-372-000	合叶螺母	Nut	(1)
15		B2552-372-000	钮钳片	Button clamp slide	(1)
16		B2555-372-0A0	钮钳杆钳左组件	Button clamp lever jaw, left A	(1)
17		B2555-372-000	钮钳杆钳(左)	Button clamp lever jaw (left)	(1)
18		B2556-372-000	钮钳支撑弹簧(左)	Button holding spring, left	(1)
19		B2559-372-000	钮钳定位销	Button clamp locating pin	(1)
20		SS-7090410-SP	用于钮钳座弹簧的螺钉	Screw 9/64-40 L=3.5	(1)
21		B2557-372-0A0	钮钳杆钳右组件	Button clamp lever jaw, right	(1)
22		B2557-372-000	钮钳杆右钳(右)	Button clamp lever jaw (right)	(1)
23		B2558-372-000	钮钳支撑弹簧(右)	Button holding spring, right	(1)
24		B2559-372-000	定位销	Button clamp locating pin	(1)
25		SS-7090410-SP	用于钮钳座弹簧的螺钉	Screw 9/64-40 L=3.5	(1)
26		B2560-372-000	钮钳止动销	Button clamp stop pin	(2)
27		SD-0640391-TP	用于杆钳的合叶螺钉	Hinge screw D=6.35 H=3.9	(2)
28		B2561-372-000	钮钳弹簧	Button clamp spring	(1)
29		SS-7150940-SP	固定提升杆的螺钉	Screw 15/64-28 L=9	(1)
30	#02	B2546-372-000	钮钳提升钩	Pick-up device lifting hook	(1)
31		B2540-372-000	合叶销	Hinge pin	1
32		B2541-372-000	轴用挡圈	snap ring	1
33		NS-6150430-SP	用于钮钳塞销的螺母	Nut 15/64-28	1
34		B2543-372-000-A	钮钳塞销	Pick-up device stopper pin	1
35		B2544-372-000	钮钳调压杆	Button clamp pressure adjusting	1
36		B2545-372-000	调压弹簧	Pressure adjusting spring	1
37		NS-6660511-SP	用于钮钳调压杆的螺母	Nut 1/4	2
38		B3130-372-000-B	手指保护架	Finger guard	1

Note#01.....For T373

#02.....For T377

二、机壳部件 Arm & miscellaneous cover components

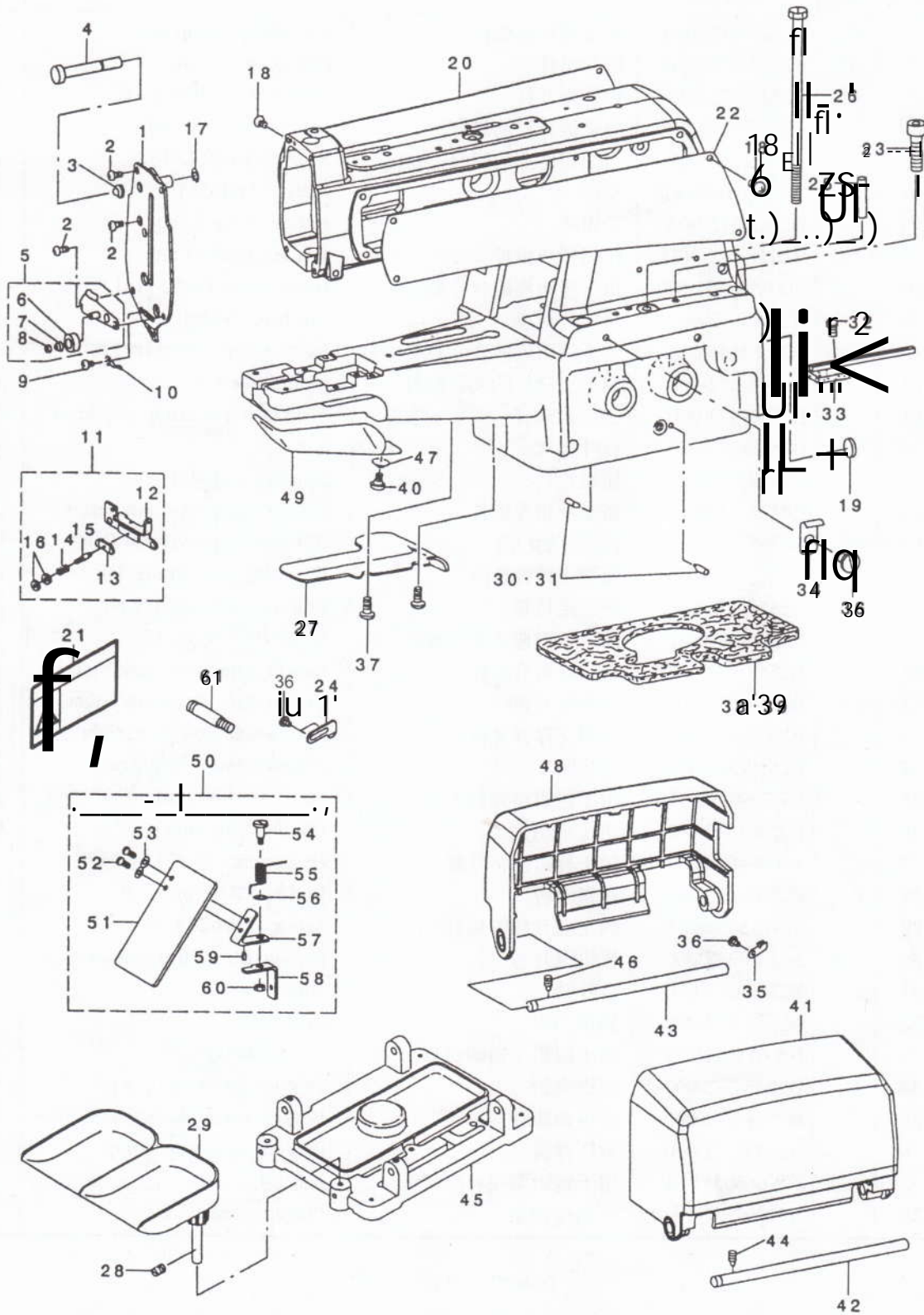

二、机壳部件/Arm & miscellaneous cover components

序号 Ref.no	注解 Note	零件图号 Part.no	名称	Description	数量 Qty
1		B260-38752	盖板	Face plate	1
2		SS-4120915-SP	螺钉	Screw 3/16-28 L=9	4
3		B3149-123-A00	弹簧	Tension spring	1
4		B3127-372-000	夹线螺栓	Nipper releasing stud	1
5	#01	260-01164	第三夹线导向装置	Thread tension guide NO.3 asm.	1
6		260-01404	第三夹线底座	Thread tension disc NO.3	(2)
7		260-01305	第三夹线弹簧	Thread tension spring NO.3	(1)
8		RE-0300000-K0	E型挡圈	E-ring 3	(1)
9		SS-7110340-SP	螺钉	Screw 11/64-40 L=3.2	1
10		B3108-372-000	第四线导向装置	Thread guide NO.4	1
11	#02	B3109-372-0A0	第三夹线总组件	Thread tension NO.3 asm.	1
12		178-02216	第三夹线调节基座	Tension adjusting base NO.3	(1)
13		101-29104	线调压板	Thread presser plate	(1)
14		B1136-850-000	夹线弹簧B	Tension spring B	(1)
15		250-02809	夹线螺栓	Thread tension stud	(1)
16		250-02808	夹线螺母	Thread tension nut	(2)
17		RE-0320000-K0	E型挡圈	E-ring 3.2	1
18		SS-4120915-SP	螺钉	Screw 3/16-28 L=9	4
19		100-04109	接地标记	Ground mark	1
20		260-12104	左盖板	Side plate, left	1
21		CM-3002001-B1	安全标牌	Safety label 12	1
22		260-12005	右盖板	side plate, right	1
23		SM-6083042-CH	螺钉	Screw M8 L=30	4
24	#02	B2712-377-000	止动板	Stopper	1
25		B1105-372-000	导销	Guide pin	2
26		B1128-372-000	连接螺栓	Set screw	1
27		B1119-373-000	底座油封	Bed oil shield	1
28		SS-8150710-SP	螺钉	Screw 15/64-28 L=7	1
29		1780-48458	钮扣盘组件	Button tray asm.	1
30		B2504-372-000	凸轮指示销	Cam indicating pin	2
31	#03	B2504-372-00A	凸轮指示销	Cam indicating pin	2
32		SS-7110840-SP	螺钉	Screw 11/64-40 L=7.8	1
33		B3503-372-0A0-A	油毡	Oil supply felt	1
34		B1127-372-000-A	盖板卡簧	side cover spring	2
35	#02	260-11809	盖板卡簧(左)	side cover spring, left	1
36		SS-7120640-SP	螺钉	Screw 3/16-28 L=6	2
37		SS-4110815-SP	螺钉	Screw 11/64-40 L=8	2
38	#03	B1104-372-A00	滴油毡 A	Oil drip felt (A) 5MM	1
39	#03	B1104-372-B00	滴油毡 B	Oil drip felt (B) 7MM	1
40		SD-0600271-SP	螺钉	Hinge screw D=6	1
41		260-11502	右滑轮盖	side cover, right	1
42		B1110-372-000	滑轮盖合叶杆	Side cover hinge shaft	1
43		B1110-377-000	滑轮盖合叶杆	Side cover shaft, left	1
44		SS-8150710-SP	螺钉	Screw 15/64-28 L=7	1
45		B1103-372-000	机器次底座	Machine sub-base	1
46		SS-8150710-SP	螺钉	Screw 15/64-28 L=7	1
47		WS-0650389-KP	弹性垫圈	Spring washer 6.5x14x17	1
48		260-11403	左盖	side cover, left	1
49		260-03608	底座活动盖	Looper cover	1
50		B3115-372-000	安全板组件	Safety plate asm.	1
51		B3120-372-000	安全板	Safety plate	(1)
52		SS-4110715-SP	螺钉	Screw 11/64-40 L=7	(2)
53		WP-0450801-SD	垫圈	Washer 4.5x10x0.8	(2)
54		SD-0601021-SP	合叶螺丝	Hinge screw D=6 H=10.2	(1)
55		139-43204	安全面板回位弹簧	Safety plate return spring	(1)
56		WP-0740516-SP	垫圈	Washer 7.4x11.8x0.5	(1)
57		B3121-372-000	安全板安装板	Safety plate installing plate	(1)
58		B3115-372-000	安全板安装基板	Safety plate installing base	(1)
59		PS-0200062-KH	塞销	Spring pin 2x6	(1)
60		NS-6110310-SP	螺钉	Nut 11/64-40	(1)
61		137-37507	悬浮螺钉	Suspension screw B	1

Note #01.....For T-373 #02.....For T-377 #03.....Selective partys

三、上轴机构零件 Looper shaft mechanism components

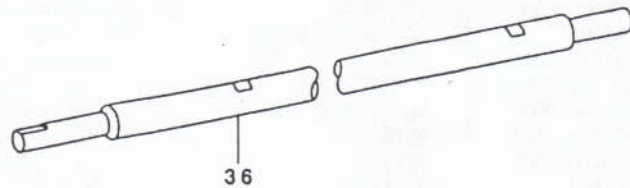
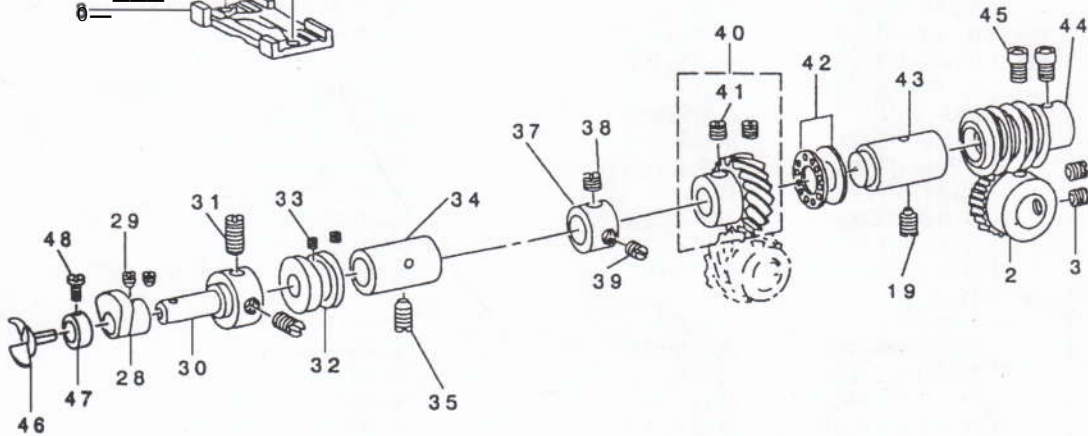
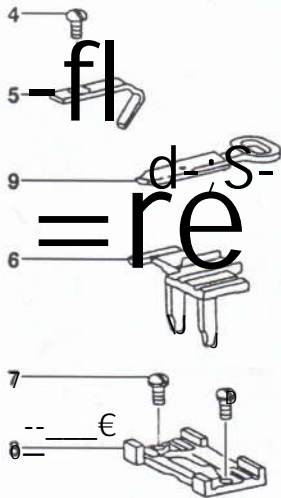
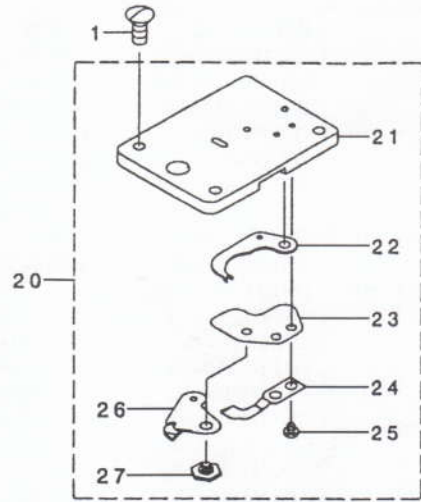
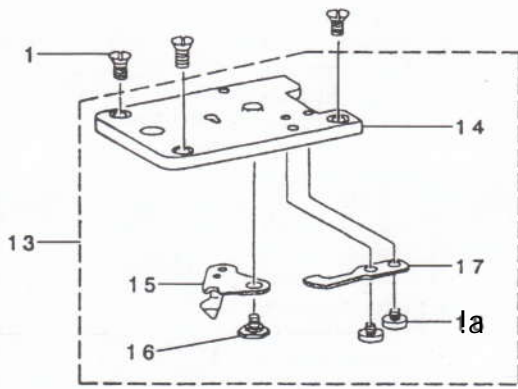

三、上轴机构部件/Looper shaft mechanism components

序号 Ref.no	注解 Note	零件图号 Part.no	名称	Description	数量 Qty
1		SS-2110920-TP	螺钉	Screw 11/64-40 L=8.5	3
2		B1220-372-000	凸轮轴从动齿轮	Cam shaft driven gear	1
3		SS-8660612-TP	螺钉	Screw 1/4-40 L=6	2
4		SS-7110840-SP	螺钉	Screw 11/64-40 L=7.8	1
5		B1242-373-000	导向线杆(打捆针导向器)	Needle guard	1
6		B1236-373-000	插入导向滑板(手指定位軛铁片)	Positioning finger yoke slide	1
7		SS-1110710-SP	螺钉	Screw 11/64-40 L=7.8	2
8		B1235-373-000	导向卡箍(压铁插孔)	Yoke slide insert	1
9		B1237-373-000	滑块(軛铁片)	Yoke slide	1
10		B1230-372-0A0	环形弹位杆(定位)	Loop positioning finger lever	1
11		SD-0640241-SP	螺钉	Hinge screw D=6.35 H=2.4	(1)
12		B1232-372-000	滚环	Loop positioning finger lever	(1)
13	#01	B1241-373-0B0	喉板组件	Throat plate asm.	1
14		B1241-373-000	喉板	Throat plate	(1)
15		B2406-373-000	可动刀组件	Moving knife asm.	(1)
16		SD-0600095-TH	合叶螺钉(旋转螺钉)	Hinge screw D=6 H=0.85	(1)
17		B2410-373-000	固定刀片	Counter knife	(1)
18		SS-7080310-SP	螺钉	Screw 1/8-44 L=3.0	(2)
19		SS-8151150-SP	螺钉	screw 15/64-28 L=10.5	1
20	#02	B1241-377-0B0	喉板座组件	Throat plate set	1
21	#01	B1241-377-0A0	喉板	Throat plate asm.	(1)
22	#02	B2703-377-0A0	滚动线板	Thread bind plate asm.	(1)
23	#02	B2702-377-000	滚动线板支撑	Thread bind support plate	(1)
24		B2410-373-000	固定刀	Counter knife	(1)
25		SS-7080310-SP	螺钉	Screw 1/8-44 L=3.0	(2)
26		B2406-373-0A0	可动刀	Moving knife asm.	(1)
27		SD-0600095-TH	螺钉	Hinge screw D=6 H=0.85	(1)
28		B1234-372-000	环形凸轮	Loop positioning finger cam	1
29		SS-8110410-TP	螺钉	screw 11/64-40 L=3.5	2
30		B1233-372-000	连接轴	cam & looper sleeve	1
31		SS-8110410-TP	螺钉	screw 15/64-28 L=4.0	2
32		B1228-372-000	后凸轮	Loop positioning finger cam re	1
33		SS-8110310-SP	螺钉	Screw 11/64-40 L=2.8	2
34		B1227-372-000	前轴套	Looper shaft bushing,front	1
35		SS-8151150-SP	螺钉	screw 15/64-28 L=10.5	1
36		B1219-372-000-A	下轴	Looper shaft	1
37		CS-1111019-SH	挡圈	Thrust collar D=11.11 W=10	2
38		SS-8660512-TP	螺钉	Screw 1/4-40 L=5	1
39		SS-8660512-TP	螺钉	Screw 1/4-40 L=5	1
40		B1224-372-0A0	上轴从动齿轮组件	Looper shaft driven gear asm.	1
41		SS-8660612-TP	螺钉	Screw 1/4-40 L=6	(2)
42		B1215-372-A00	端面球轴承	Thrust ball bearing	1
43		B1222-372-000	轴套(后)	Looper shaft bushing, rear	1
44		B1221-372-000	从动蜗轮	Driven worm gear	1
45		SS-6660712-TP	螺钉	Screw 1/4-40 L=7.0	2
46		B1239-372-000	钩圈	Looper	1
47		CS-0790721-TH	挡圈	Thrust collar D=7.94 W=7	1
48		SS-7090620-TP	螺钉	Screw 9/64-40 L=6.1	1

Note #01.....For JK-T373 #02.....For JK-T377

四、穿线器和过线部件 Nipper & tension parts components

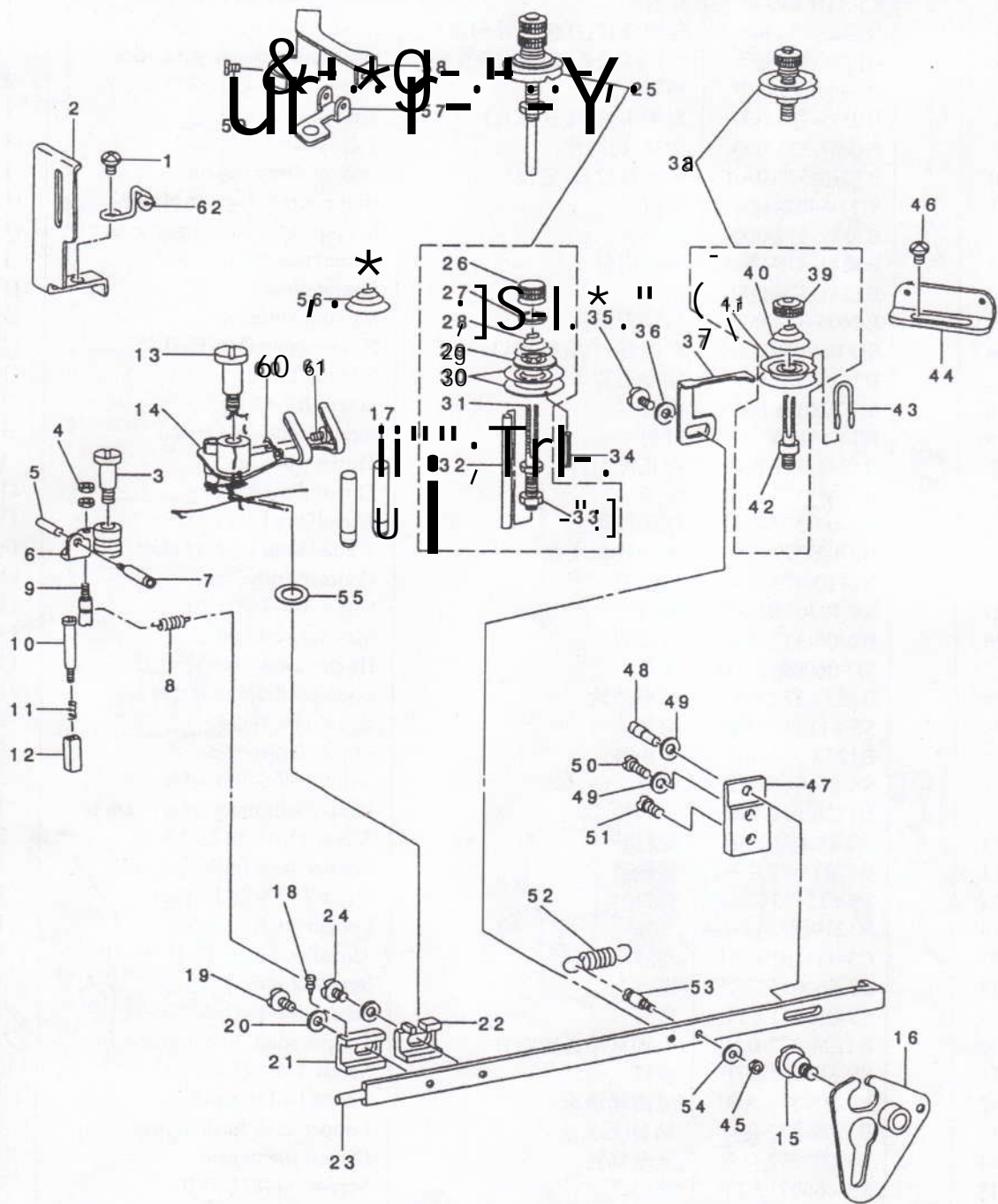

四、绕线和过线部件/Nipper & tension parts components

序号 Ref.no	注解 Note	零件图号 Part.no	名称	Description	数量 Qty
1		SS-4150915-SP	螺钉	Screw 15/64-28 L=9	1
2		B1421-372-000	针杆护罩	Needle bar guard	1
3		SD-0791271-SP	螺钉	Hinge screw D=7.94 H=12.7	1
4		NS-6080210-SP	螺母	Nut 1/8-44	2
5		B2035-372-000	放线螺母	Nut	1
6		260-00950	导线装置	Nipper compl.	1
7		B2034-372-000	放线螺栓	Thread releasing screw stud	1
8		B2037-372-000	夹线杆底座弹簧	Nipper bar block spring	1
9		B1236-372-000	夹线杆底座弹簧螺钉	Nipper bar block spring screw	1
10		SD-0402001-TP	螺钉	Hinge screw D=4 H=20	1
11		B2029-372-000	夹线座弹簧	Nipper block spring	1
12		B2028-372-000	夹线座	Nipper block	1
13		SD-0791503-SP	螺钉	Hinge screw D=7.94 H=15	1
14		260-01560	引线杆组合	Thread pull-off lever asm.	1
15		SD-0790802-SP	驱动杆螺栓	Hinge screw D=7.94 H=8	1
16	#01	260-00455	夹线杆驱动杆设备	Nipper bar actuating lever asm.	1
17		B2024-372-000-A	L形导线钩	Thread guide pin	2
18		B2012-372-000	夹线杆底座弹簧销	Nipper bar block spring pin	1
19		SS-6120930-TP	螺钉	Screw 3/16-28 L=9	1
20		WP-0501016-SD	垫圈	washer 5x10.5x1	2
21		B2011-372-000	夹线杆底座	Nipper bar block	1
22		B2010-372-000	夹线杆底座(后)	Tension lever rocking piece	1
23		260-01909	夹线杆	Nipper bar	1
24		SS-6120930-TP	螺钉	Screw 3/16-28 L=9	1
25	#02	B2019-372-0A0	2号夹线杆组件	Tension post asm. NO.2	1
26	#01	B3116-372-000	调节螺母	tension nut	(1)
27	#02	229-214070	停转器	Rotation stopper	(1)
28	#02	B2021-372-000	2号夹线压力弹簧	Thread tension spring NO.2	(1)
29	#02	B3132-012-000	夹线提升垫片	Tension disc holder	(1)
30		B2016-372-000	夹线圆盘(夹线板)	Tension disc	(2)
31		B2019-372-000	2号夹线杆	Tension post NO.2	(1)
32		B2020-372-000	放压枢轴(松线辅钉)	Tension release pin	(1)
33		NS-6160520-SP	平衡轴螺母	Nut 1/4-24	(1)
34		PS-0300162-KH	夹线圆盘销	spring pin 3x16	1
35		SS-6120930-TP	螺钉	Screw 3/16-28 L=9	1
36		WP-0501016-SD	垫圈	washer 5x10.5x1	1
37		B2029-372-000	释压杆	Thread tension releasing lever	2
38		260-05157	1号夹线器组件	Thread tension asm.(NO.1)	1
39		B3125-012-000	夹线螺母	Thread tension nut	(1)
40		B2017-372-000	1号夹线弹簧	Tension spring NO.1	(1)
41		B2016-372-000	夹线圆盘	Tension disc	(2)
42		B2015-372-000	1号夹线器轴	Thread tension staff NO.1	(1)
43		B2014-372-000-A	导线钩	Thread guide pin	1
44		B2039-373-000	1号导线钩	Thread guide NO.1	1
45		NS-6080340-SP	螺母	Nut 1/8-44	1
46		SS-4150915-SP	螺钉	Screw 15/64-28 L=9	1
47		B2005-372-000	夹线杆滑块	Nipper bar bearing block	1
48		B2006-372-000	调节螺母	Adjusting screw	1
49		WP-0480856-SP	垫圈	Washer 4.8x8.4x0.8	2
50		SS-6121610-TP	螺钉	Screw 3/16-28 L=15.5	1
51		SS-6121050-SP	螺钉	Screw 3/16-28 L=9.5	1
52		B2008-372-000	2号钳杆弹簧	Thread tension spring NO.2	1
53		B2007-372-000	夹线杆弹簧螺钉	Nipper bar spring screw	1
54		WP-0371016-SD	垫圈	Washer 3.7x8x1	1
55		135-07504	垫圈	Washer	1
56		B3114-232-000	2号夹线弹簧	Thread tension spring NO.2	1
57	#02	B2715-377-000	导线钩	Thread guide	1
58	#02	B2716-377-000	杠杆	Lever	1
59	#02	SS-7090540-TP	螺钉	Screw 9/64-40 L=5	1
60	#01	B2040-373-000	导线钩	Thread guide	1
61	#01	SS-4090415-SP	螺钉	Screw 9/64-40 L=4	1
62	#01	B2038-372-000	2号导线钩	Thread guide NO.2	1

Note #01.....For -T373 #02.....For -T377

T373, T377

五、送料盘部件 Feed plate components

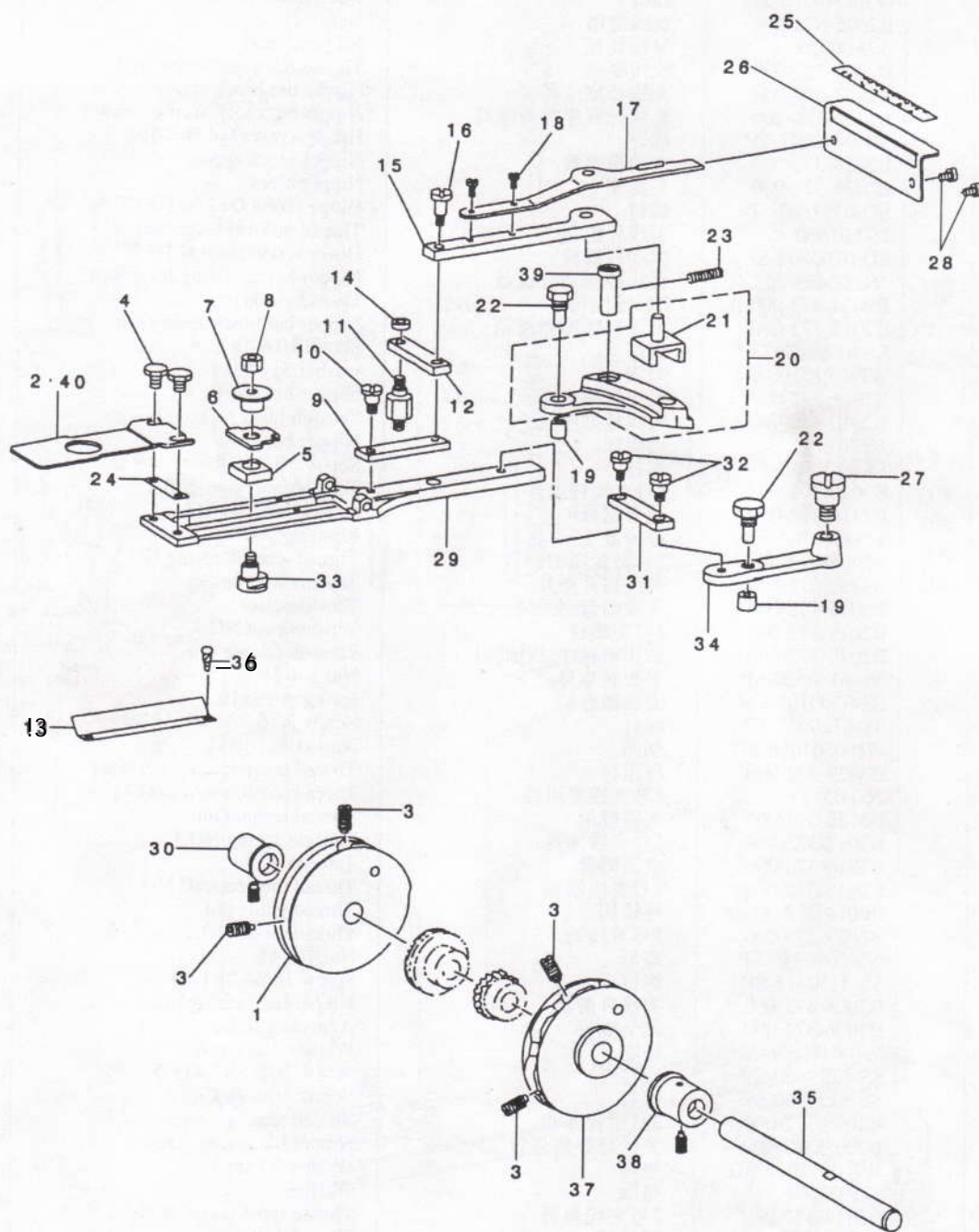

五、送料盘部件/Feed plate components

序号 Ref.no	注解 Note	零件图号 Part.no	名称	Description	数量 Qty
1		B2506-373-000-A	纵向送料凸轮	Longitudinal feed cam	1
2		B2529-373-000	小钮扣送料盘/板	Feed plate, small button	1
3		SS-8681412-TP	螺钉	Screw 9/32-28 L=13.5	4
4		SS-9120643-TP	螺钉	Screw 3/16-28 L=6	2
5		B2524-372-000	指示器销轴承座	Indicator pin bearing block	1
6		B2525-373-N00	交叉送料指示器	Crosswise feed indicator	1
7		B2526-372-000	交叉送料指示器销	Crosswise feed indicator pin	1
8		NS-6160520-SP	螺母	Nut 1/4-24	1
9		B2518-372-000-A	滑板连接杆	slide plate connecting link A	1
10		SD-0640481-SP	合叶螺钉	Hinge screw D=6.35 H=9.6	1
11		B2521-372-000	双头螺栓	Stud	1
12		B2519-372-000	中部连接杆	Intermedi connecting link	1
13		B2528-372-000-A	交叉送料刻度盘	Crosswise feed graduated plate	1
14		NS-6120630-SP	螺母	Nut 3/16-28	1
15		B2513-372-000	手柄及指示器弹簧手柄	Indicator spring connecting link	1
16		SD-0640961-SP	合叶螺钉	Hinge screw D=6.35 H=9.6	1
17		B2515-372-000	手柄及指示弹簧	Handle & indicator spring	1
18		SS-4090615-SP	螺钉	Screw 9/64-40 L=6	2
19		B2507-372-000	凸轮滚轱	Cam roll	2
20		B2511-372-0A0	纵向送料杆滑块组件	Lengthwise feed lever asm.	1
21		B2512-372-000	纵向送料轴滑块	Lengthwise feed lever slide block	(1)
22		B2508-372-000	凸轮滚轱螺栓	Cam roll screw stud	2
23		SS-8152030-SP	垫圈	Screw 15/64-28 L=20	1
24	#1	B2717-377-000	隔离板	Spacer	1
25		B2563-372-000	纵向送料刻度盘	Lengthwise feed graduated plate	1
26		B2564-372-000	纵向送料刻度盘底座	Plate base	1
27		SD-0791051-SP	螺钉	Hinge screw D=7.94 H=10.5	1
28		SS-4120615-SP	螺钉	Screw 3/16-28 L=6	2
29		B2522-373-000-A	滑板滑床板	Feed plate	1
30		B2503-372-000	凸轮轴左轴衬	Cam shaft bushing, left	1
31		B2519-372-000	十字形送料连接杆	Intermedi connecting link	1
32		SD-0640481-SP	螺钉	Hinge screw D=6.35 H=4.8	2
33		B2523-372-000	合叶螺钉	Hinge screw for crosswise feed	1
34		B2510-372-000-A	交叉送料杆	Crosswise feed lever	1
35		B2501-372-000-A	凸轮轴	Cam shaft	1
36		B1161-227-000	铆钉	Rivet	2
37		B2505-373-000-A	交叉送料凸轮	Lateral feed cam.	1
38		B2502-372-000	凸轮轴右轴衬	Cam shaft bushing, right	1
39		B2509-372-000-A	杆销	Feed stud	1
40		B2529-373-B00-A	中等规格钮扣送料盘/板	Feed plate medium size button	1

Note #01.....For -T377

В. 铆钳提升部件 Button clamp lifter components

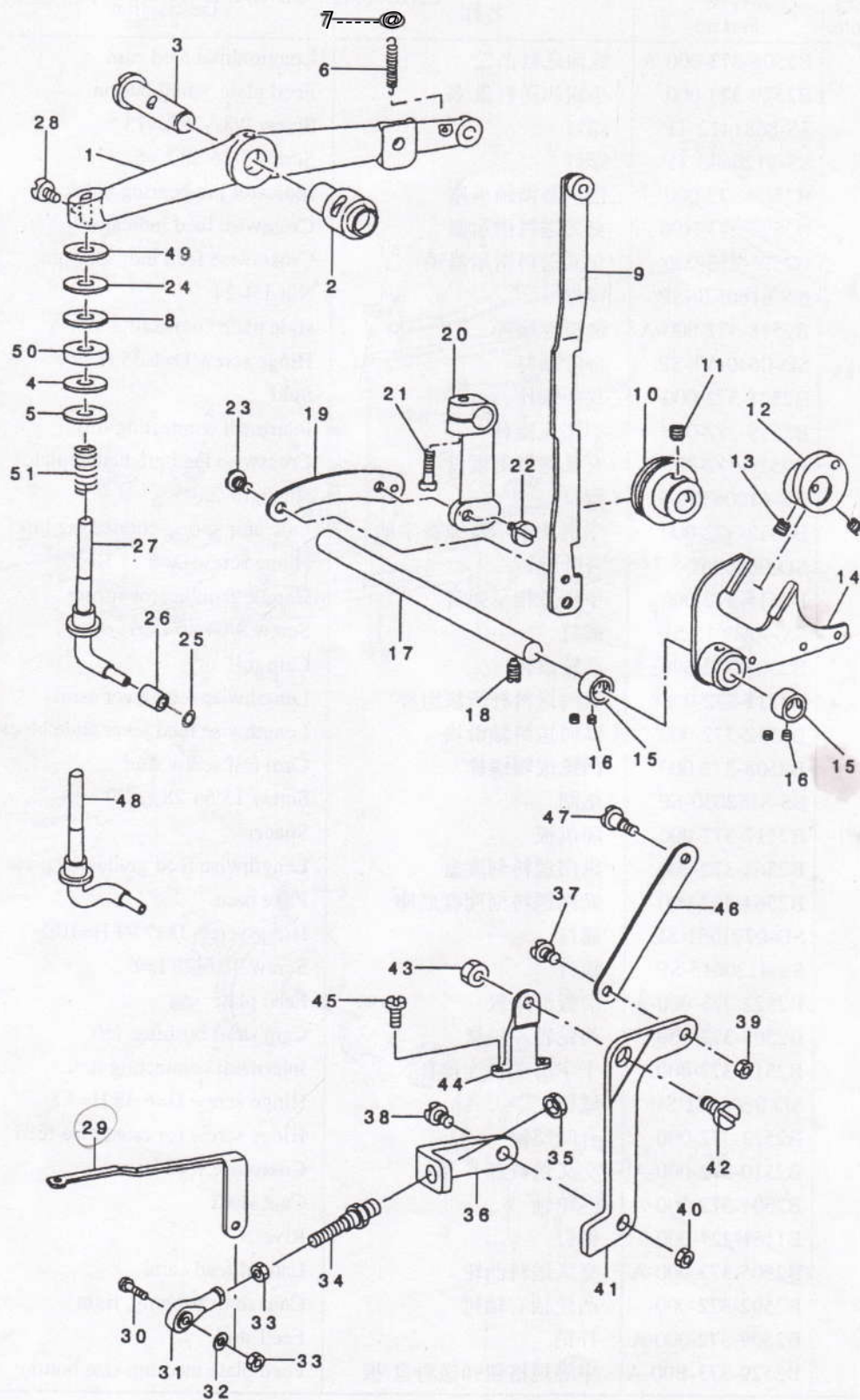

六、钮钳提升部件/Button clamp lifter components

序号 Ref.no	注解 Note	零件图号 Part.no	名称	Description	数量 Qty
1		B4412-373-000-A	钮钳提升杆	Lifting lever	1
2		B1407-372-000	轴衬	Bushing	1
3		B1408-372-000	提升杆轴	Lifting lever shaft	1
4	#4	WP-0751576-SD	垫圈	Washer 7.5x19x1.5	2
5	#4	WP-0851846-SD	垫圈	Washer 8.5x22.0x1.8	2
6		B4419-372-000	夹线杆动作杆弹簧	Nipper bar actuating lever spring	1
7		B4418-372-000	垫圈	Washer	1
8	#3	WP-0704016-SP	垫圈	Washer 7x20x4	1
9		B4411-372-000	钮钳提升杆	Button clamp lifting link	1
10		B4410-372-000	滑动滚筒	sliding roller	1
11		SS-8660612-TP	螺钉	Screw 1/4-40 L=6	1
12		260-03301	偏心轮组件	Eccentric cam asm.	1
13		SS-8660612-TP	螺钉	Screw 1/4-40 L=6	2
14		B4401-372-000	杠杆啮合钮钳提升连杆驱动离心	Button clamp lifting link	1
15		CS-090816-SH	止推环(挡圈)	Thrust collar D=9.5 W=8	2
16		SS-8110410-TP	螺钉	Screw 11/64-40 L=3.5	4
17		B4404-372-000-A	固定螺丝曲(柄)轴杠杆轴	Lever shaft	1
18		SS-8151150-SP	螺钉	Screw 15/64-28 L=10.5	1
19		B4408-372-000	钮钳提升联结杆	Lifting link connecting link	1
20		B4406-372-000-C	啮合钮钳提升连接杆	Lifting plate guide rod	1
21		SS-6121610-TP	螺钉	Screw 3/16-28 L=15.5	1
22		SD-0640481-SP	合叶螺丝	Hinge screw D=6.35 H=4.8	1
23		SD-0640211-SP	合叶螺丝	Hinge screw D=6.35 H=2.1	1
24	#3	WP-0703516-SP	垫圈	Washer 7x20x3.5	1
25		WP-0480856-SP	垫圈	Washer 4.8x8.4x0.8	1
26		B4417-372-000	钮钳提升杆滚动	Button clamp lifting rod roll	1
27	#1	260-00653	钮钳提升杆	Button clamp lifting rod compl	1
28		SM-6061002-TP	螺钉	Screw M6 L=10	1
29		B2404-373-R00	前切线连接杆	Connecting link, front	1
30	#1	B2413-373-000	连接螺栓	Joint stud	1
31		B1632-180-000	送料调节连接体	Feed adjusting joint	1
32		WP-0510516-SD	垫片	Washer 5.1x7.5x0.5	1
33		NM-6050001-SP	螺母	Nut M5	2
34		B2412-373-000	连接螺钉	Connecting screw	1
35		NS-6680410-SP	螺母	Nut 9/32-28	2
36		B2503-373-000-A	后切线连接杆	Connecting link, rear	1
37		SD-0640323-TP	合叶螺丝	Hinge screw D=6.35 H=3.2	1
38		SD-0790402-TP	合叶螺丝	Hinge screw D=7.94 H=4	1
39		NS-6620310-SP	螺母	Nut 3/16-32	1
40		NS-6150310-SP	螺母	Nut 15/64-28	1
41		260-02006	切线杆	Thread trimming lever	1
42		SD-0790311-TP	合叶螺丝	Hinge screw D=7.94 H=3.1	1
43		NS-6110420-SP	螺母	Nut 11/64-40	1
44		B2405-373-000	切线杆底座	Thread trim lever base	1
45		SS-7111410-TP	螺钉	Screw 11/64-40 L=14	2
46		B2401-373-000	切线连杆	Thread trimming link	1
47		SD-0641322-TP	合叶螺丝	Hinge screw D=6.35 H=13.2	1
48	#2	B4416-377-0A0	钮钳提升组件	Lifting bar asm.	1
49	#3	WP-0704516-SP	垫圈	Washer 7x20x4.5	1
50		B4420-373-000	缓冲垫	cushion	1
51		D9219-555-B00	安全弹簧	Safety magnet	1

Note #01.....For -T373 #03.....Selective part #04.....Selective parts
 #02.....For -T377 (Use of one part) (Use of one or two parts)

七、针杆滑轮轴部件 / Needle driving pulley shaft components

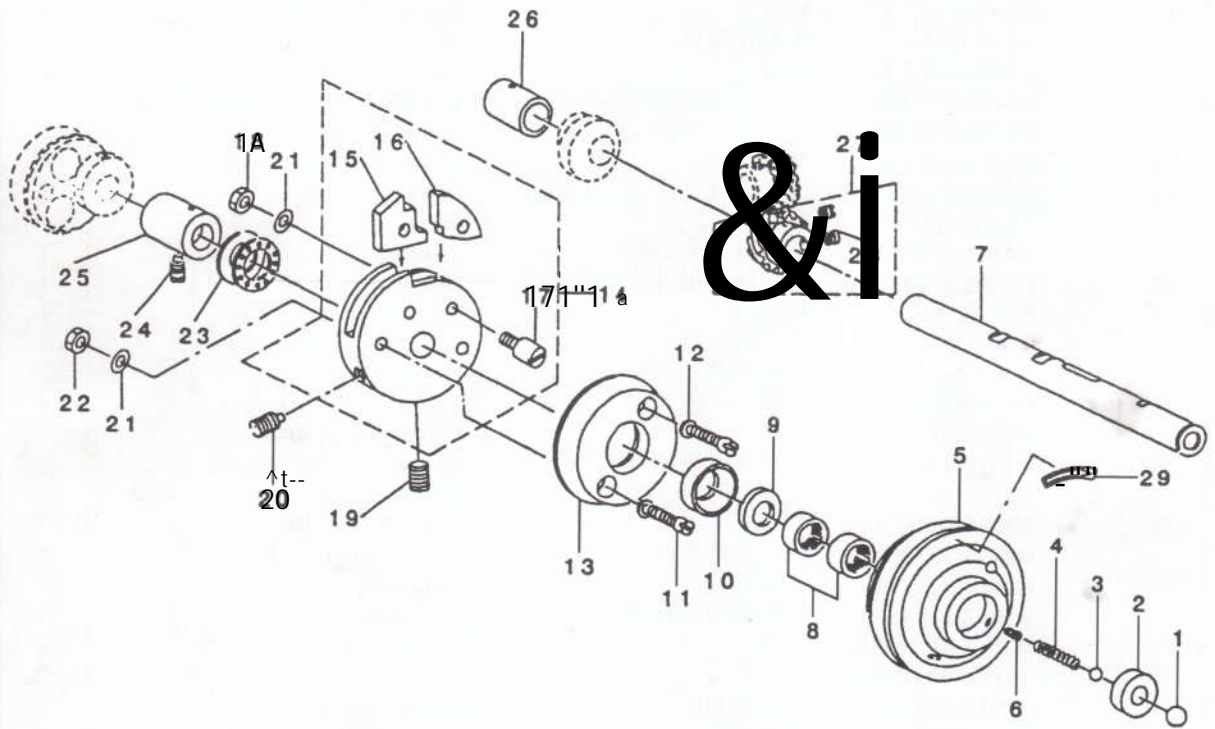

七、推针滑轮轴部件/Needle driving pulley shaft components

序号 Ref.no	注解 Note	零件图号 Part.no	名称	Description	数量 Qty
1		B1203-372-000	大滚珠	Ball large	1
2		B1204-372-000	主动轧辊支承/驱动转动承座	Pulley insert	1
3		B1246-372-000	小滚珠	Ball small	1
4		B1205-372-000	弹簧	Spring	1
5		B1202-372-000	驱针转筒滑轮	Needle driving pulley	1
6		SS-8110750-SP	螺钉	Screw 11/64-40 L=6.5	1
7		B1201-373-000	驱针滑轮轴	Needle driving pulley shaft	1
8		B1243-372-000	滚针轴承	Needle bearing	2
9		B1206-372-000	滑油绳	Grease retaining wick	1
10		B1207-372-000	密封垫	retaining washer	1
11		SS-6152440-SP	螺钉	Screw 15/64-28 L=23.5	2
12		WP-0621026-SP	垫圈	Washer 6.2x9.5x1	2
13		B1208-372-000	滑轮离合器圆盘驱针	Needle driving pulley clutch D	1
14		B1210-372-000	止动圆盘组件	Stop motion disc asm.	1
15		B1211-372-000	止动圆盘止动爪	Stop motion disc pawl (A)	(1)
16		B1212-372-000	止动圆盘销	Stop motion disc latch (B)	(1)
17		B1213-372-000	螺钉	Screw	(2)
18		NS-6150430-SP	螺母	Nut 15/64-28	2
19		SS-8707042-TP	定位螺钉	Screw 5/16-24 L=10.0	1
20		SS-8701782-TP	紧固螺钉	Screw 5/16-24 L=17.0	1
21		WS-0651310-KP	弹性垫圈	Spring washer 6.5x11x1.3	4
22		NS-6150430-SP	螺母	Nut 15/64-28	2
23		B1215-372-B00	滚动轴承	Thrust ball bearing	1
24		SS-8151150-SP	螺钉	Screw 15/64-28 L=10.5	1
25		B1216-372-000	滑轮轴右轴衬	Pulley shaft bushing, right	1
26		B1223-372-000	滑轮轴左轴衬	Pulley shaft bushing, left	1
27		B1217-372-0A0	从动齿轮组件	Driving gear asm.	1
28		SS-8660612-TP	螺钉	Screw 1/4-40 L=6	(2)
29		CM-5002000-01	方向标签	Direction label.	1

八、针杆驱动机构 / Needle bar driving mechanism components

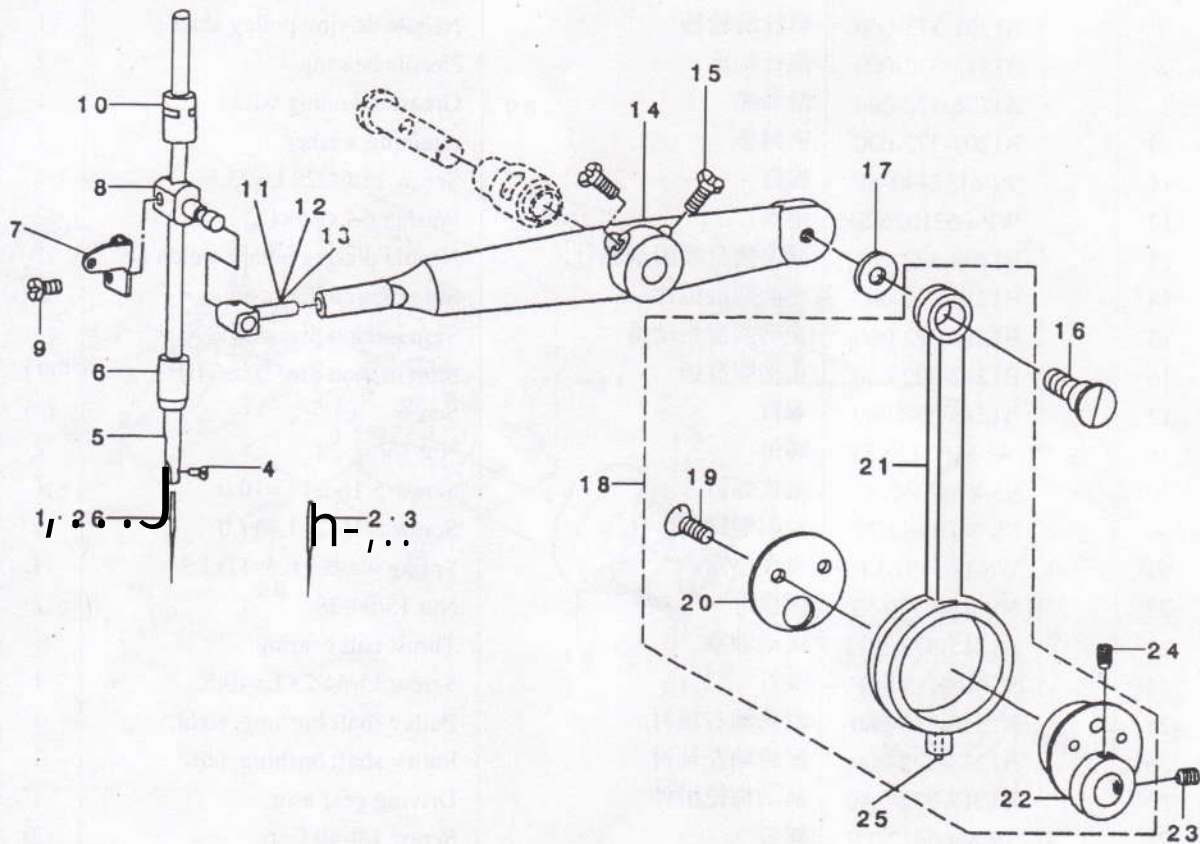

八、针杆驱动机构部件/Needle bar driving mechanism components

序号 Ref.no	注解 Note	零件图号 Part.no	名称	Description	数量 Qty
1	#01	MTQ-700B1800	机针	Needle TQx7 #16	1
2	#01	MTQ-700B2000	机针	Needle TQx7 #20	1
3	#02	MTQ-700B1800	机针	Needle TQx7 #18	1
4		SS-7080510-TP	螺钉	Screw 1/8-44 L=4.5	1
5		B1401-372-000-A	针棒	Needle bar	1
6		B1403-372-000-A	针棒下轴衬	Needle bar bushing lower	1
7		B3112-372-000	导线钩	Needle bar balance	1
8		B3113-372-000	针棒轴承座钳	Needle bar clamp	1
9		SS-6091210-TP	螺钉	Screw 9/64-40 L=12	1
10		B1402-372-000	针棒上轴衬	Needle bar bushing,upper	1
11	#03	B1406-372-000	针棒轴衬座	Needle bar bearing block	1
12	#03	B1406-372-00A	针棒轴衬座	Needle rod slide block	1
13	#03	B1406-372-00B	针棒轴衬座	Needle rod slide block B	1
14		B1409-372-000-B	针棒杆	Needle bar rocking pipe	1
15		SM-9061403-CP	螺钉	Screw M6 L=14	2
16		SD-0950806-SH	合叶螺丝	Hinge screw D=9.53 H=8	1
17		B1425-372-000	垫圈	washer 5x10.5x1	1
18		B1424-372-000	曲柄连杆组件	Crank rod asm.	1
19		SS-2110920-TP	螺钉	Screw 1/64-40 L=8.5	(2)
20		B1423-372-000	盖板	holder	(1)
21		B1424-372-000	连杆	rod	(1)
22		B1422-372-000	偏心凸轮	Eccentric cam	(1)
23		SS-8660612-TP	螺钉	Screw 1/4-40 L=6	1
24		SS-8660942-TP	螺钉	Screw 1/4-40 L=8.5	1
25		B1419-372-000	油线	Oil wick	1
26	#01	MTQ-100B1600	机针	Needle TQx1 #16	1

Note #01.....For T373

#02.....For T377

#03.....Selective parts

п. 止动机构部件/stop motion mechanism components

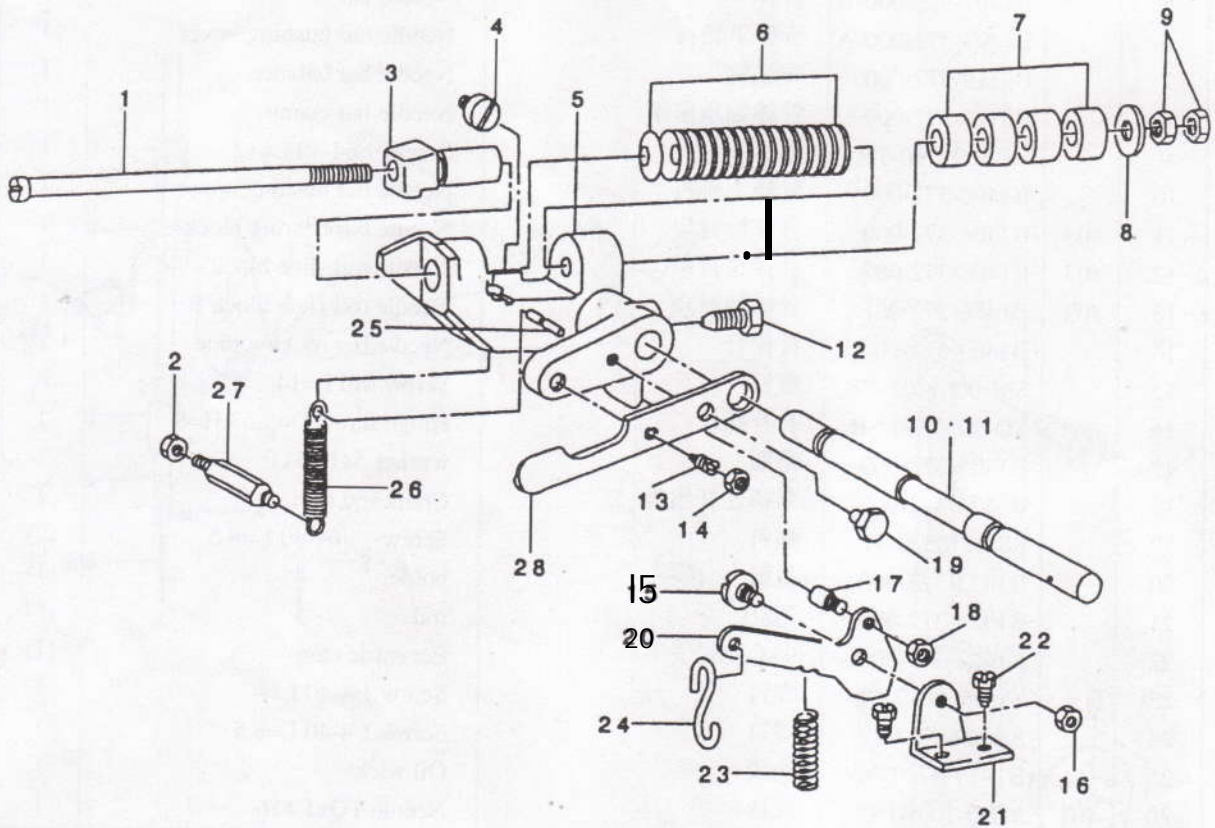

九、 止动机构部件/Stop motion mechanism components

序号 Ref.no	注解 Note	零件图号 Part.no	名称	Description	数量 Qty
1		B2605-372-000	止动柱塞杆	Stop motion plunger rod	1
2		NS-6150310-SP	螺母	Nut 15/64-28	1
3		B2604-372-000	止动柱塞/冲杆	Stop motion plunger	1
4		SS-6151040-SP	螺钉	Screw 15/64-28 L=10	1
5		B2602-372-000-A	止动柱塞杆	Stop motion plunger lever	1
6		B2606-372-000	圆盘弹簧	Stop motion disc spring	30
7		B2608-280-000	橡胶垫圈	Rubber cushion	4
8		B8220-804-000	垫圈	washer 5x10.5x1	1
9		NS-6680410-SP	调节螺母	Nut 9/32-28	2
10	#01	B2601-373-N00-A	止动杆轴	Stop-motion shaft	1
11	#02	B2601-377-000	止动杆轴	Stop-motion shaft	1
12		B2603-372-000	螺钉	Screw	1
13		SS-8151570-SP	螺钉	Screw 15/64-28 L=15.0	1
14		NS-6150310-SP	螺母	Nut 15/64-28	1
15		SD-0680271-SP	合叶螺丝	Hinge screw D=6.80 H=2.7	1
16		NS-6150310-SP	螺母	Nut 15/64-28	1
17		B2615-372-000	停止螺钉	Stop screw	1
18		NS-6150310-SP	螺母	Nut 15/64-28	1
19		SM-9061003-CP	螺钉	Screw M6 L=10	1
20		B2614-372-000	止动分离杆	Stop motion trip lever	1
21		B2612-372-000	止动分离杆座	Stop motion trip lever bracket	1
22		SS-9150860-SP	螺钉	Screw 15/64-28 L=8	2
23		B2616-372-000	用于分离杆弹簧	Spring	1
24		B8133-019-000	“S”形链钩	S shaped hook	1
25		B2608-372-000	止动杆恢复弹簧销	Stop motion lever spring pin	1
26		B2609-372-000	止动杆恢复弹簧	Stop motion lever spring	1
27		B2610-372-000	螺丝栓	Screw stud	1
28		B2611-372-000	止动圆盘适用压力杆	Stop motion disc pressure lever	1

Note #01.....For T373

#02.....For T377

十、选线部件/Sitch selecting parts components

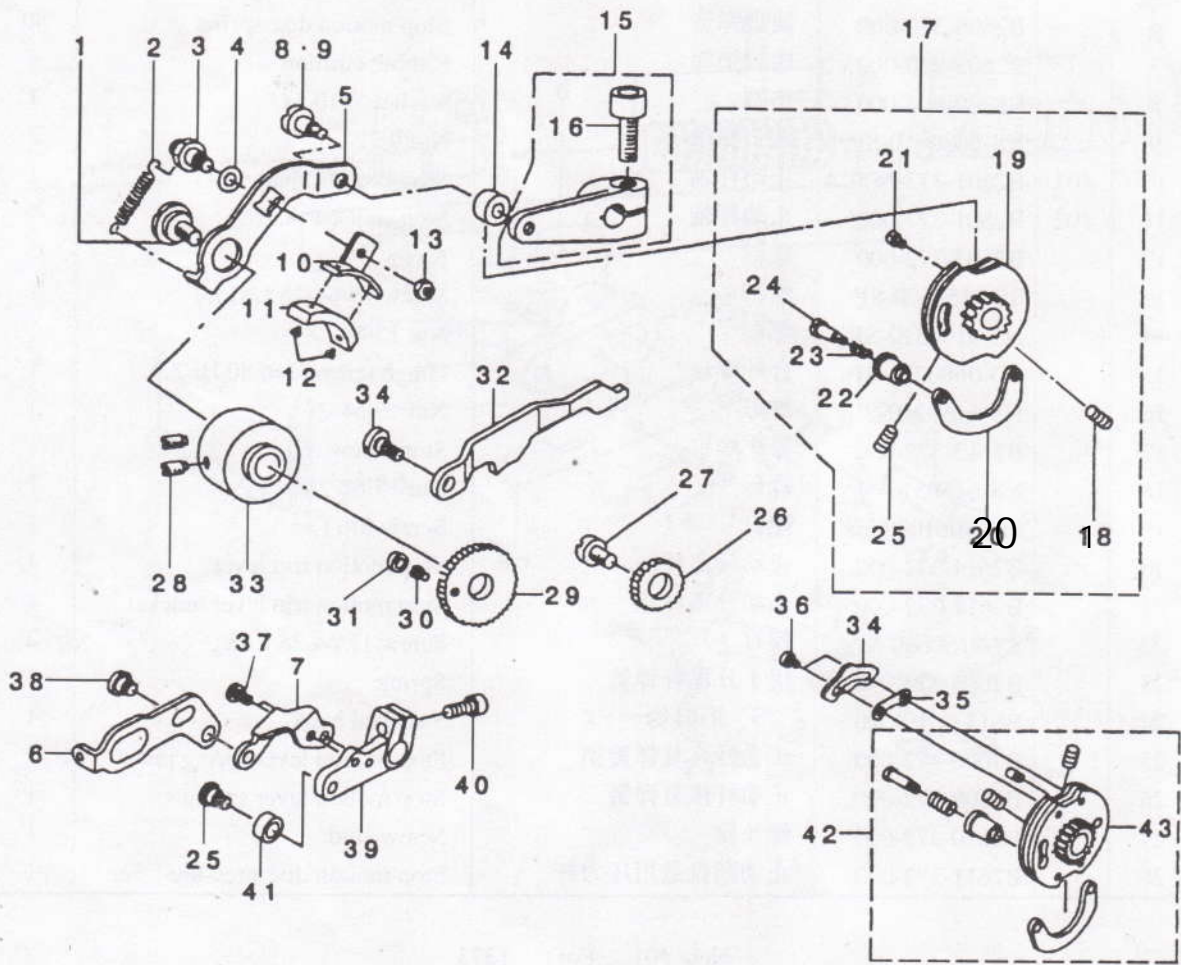

十、选线部件/Stitch selecting parts components

序号 Ref.no	注解 Note	零件图号 Part.no	名称	Description	数量 Qty
1		SD-1127321-SP	螺钉	Hinge screw D=12.70 H=3.2	1
2		B2643-372-000	摩擦片弹簧	Spring for friction plate	1
3		B2638-372-000-A	摩擦片转动轴	Friction plate rotating shaft	1
4		WP-0850002-SP	垫圈	Washer 8.5x18x1.6	1
5	#01	B2636-372-000-A	减速杆	Speed slowing lever	1
6	#02	B2637-377-000	减速杆	Speed slowing lever	1
7	#02	B2713-377-000	调节板	Fitting plate	1
8	#01	SD-0791331-SP	螺钉	Hinge screw D=7.94 H=13.3	1
9	#02	SD-0710701-SH	螺钉	Hinge screw	1
10		B2639-372-000	摩擦片座	Friction plate holder	1
11		B2640-372-000	减速摩擦片	Speed slowing friction plate	1
12		B3211-232-000	销钉	Positioning pin	2
13		NS-6110310-SP	螺母	Nut 11/64-40	1
14	#01	B2619-372-000	止动分离杆凸缘滚辗	Stop motion tripping lever cam	1
15	#01	B2618-372-0A0-B	止动分离杆组件	Stop motion tripping lever asm	1
16		SM-6082502-TP	螺钉	Screw M8 L=25	(1)
17	#01	B2621-372-0B0	止动凸轮组件	Stop motion cam asm.	1
18		SS-8150912-TH	螺钉	Screw 15/64-28 L=9	(2)
19		B2623-372-000	止动凸轮	Stop motion cam shoe	(1)
20		B2623-372-000	止动凸轮底板	Stop motion cam shoe	(1)
21		B2624-372-000	用于止动凸轮的螺钉	Screw for stop motion cam shoe	(1)
22		B2625-372-000	止动凸轮旋钮	Stop motion cam knob	(1)
23		B2626-372-000	弹簧	Spring	(1)
24		SD-0481451-SP	螺钉	Hinge screw D=4.80 H=14.5	(1)
25	#02	SD-0790431-SP	螺钉	Hinge screw D=7.94 H=4.3	1
26		B2629-372-000	选线正齿轮 (中间)	Stitch selecting spur gear, MI	1
27		B2628-372-000-A	齿轮轴	Intermediate gear shaft	1
28		SS-8151150-TP	螺钉	Screw 15/64-28 L=10.5	2
29		B2630-372-000-A	选线正齿轮	Gear, large	1
30		B2631-372-000	螺钉	Screw	1
31		B2632-372-000-A	滚圈	Roll	1
32		B2642-372-000	选线杆	Stitch adjusting lever	1
33		B2635-372-000-A	减速摩擦轮	Speed slowing friction wheel	1
34	#02	B2714-377-000	线约束槽	Thread bind notch	1
35	#02	B2719-372-000	垫片	Spacer	1
36	#02	SS-6090560-TP	螺钉	Screw 9/64-40 L=4.5	2
37	#02	SS-7110840-SP	螺钉	screw 11/64-40 L=7.8	2
38	#02	SD-0800341-SP	螺钉	Hinge screw D=8 H=3.4	1
39	#02	B2618-377-000	线迹调节臂	Stitch adjusting arm	1
40	#02	SM-6061602-TN	螺钉	Screw M6 L=16	1
41	#02	B2619-377-000	线迹调节滚圈	Stitch adjusting roller	1
42	#02	B2621-377-0B0	线迹调节凸轮组件	Stitch adjusting cam set	1
43	#02	B2621-377-0A0	线迹调节凸轮	Stitch adjusting cam asm.	(1)

Note #01.....For -T373

#02.....For -T377

T373, T377

二、捆线部件 Thread bind notch components

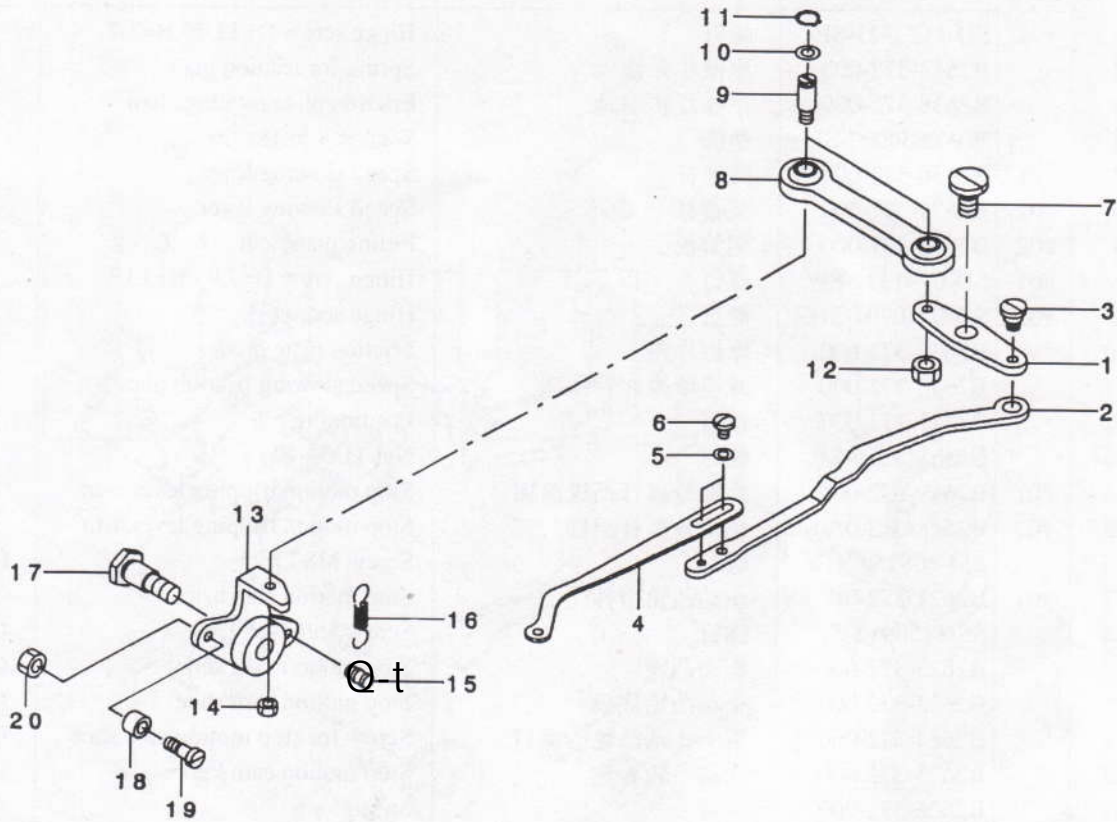

料号 Ref.no	分解 Note	零件图号 Part.no	名称	Description	数量 Qty
1		B2707-377-000	捆线杠杆	Thread bind lever	1
2		B2706-377-000	大联接板	Connecting plate, large	1
3		SD-064321-SP	螺钉	Hinge screw D=6.35 H=3.2	1
4		B2765-377-000	小联接板	Connecting plate, small	1
5		WP4440800-SD	垫圈	Washer M4	2
6		SS-7090540-TP	螺钉	Screw 9/64.40 L=5	2
7		SD(720)331-SP	螺钉	Hinge screw D=7.24 H=3.3	1
8		D2509-282-A00	连接杆	Work camp foot ball link	1
9		B2708-377-000	捆线连接杆轴	Thread bind link shaft	2
10		WP-0621026-SP	垫圈	Washer 6'2x9.5x1	2
11		RC-0560711-KP	密环	Retaining ring	2
12		NS-6110310-SP	螺母	Nut 11/64-40	1
13		B2769-377-0A0	捆线臂组件	Thread bind arm asm.	1
14		NS-6110310-SP	螺母	Nut 11/64-40	1
15		B1110-280-000	切线连接弹簧杆	Thread cutting link spring fac	1
16		R2711-377-000	弹簧	Spring	1
17		SD-0801021-TP	螺钉	Hinge screw D=8 H=10.2	1
18		B2718-377-000	滚筒	Roller	1
19		SD-0460571-CP	螺钉	Hinge screw D4.6 H=5.7	1
20		NS-6110310-SP	螺母	Nut 11/64-40	1

十二、线架部件/Thread stand components

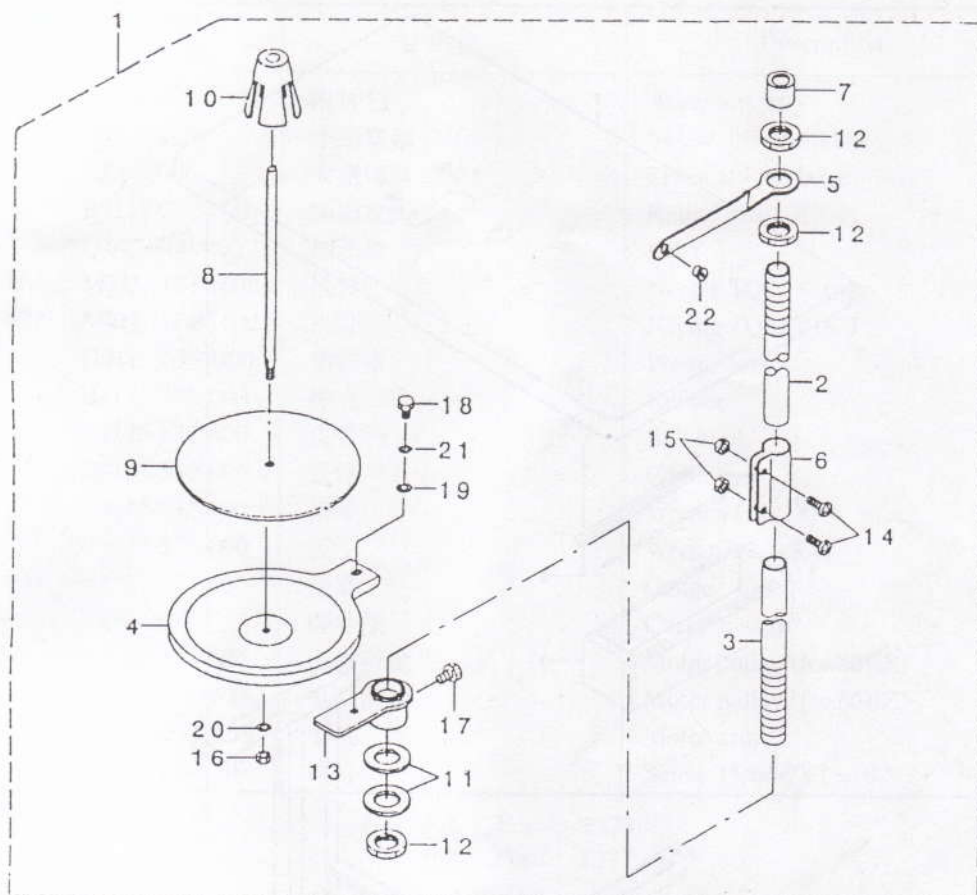

序号 Ref.no	注解 Note	零件图号 Part.no	名称	Description	数量 Qty
1		260-08359	线架组件	Thread stand asm.	1
2		229-30408	线架杆上节	Spool rest rod, upper	(1)
3		229-30309	线架杆下节	Spool rest rod, lower	(1)
4		260-08300	线架盘	Thread stand holder plate	(1)
5		260-08409	线架导线杆	Thread raising thread guide A	(1)
6		229-31307	线架杆节头	Spool rest rod joint	(1)
7		229-31406	线架杆顶防护橡皮	Spool rest rod rubber cap	(1)
8		229-31000	线盘钉	Spool pin	(1)
9		229-30903	线盘垫	Spool rest cushion	(1)
10		229-31109	线团防松垫	Spool retainer	(1)
11		WP-1702600-S0	垫圈	Washer 17x30x2.6	(2)
12		NM-6160511-SE	螺母	Nut M16x1.5	(3)
13		260-0855730408	线架支架	spool rest bracket asm.	(1)
14		SM-4051405-SE	螺钉	Screw M5 L=14	(2)
15		NM-6050001-SE	螺母	Nut M5	(2)
16		NM-6050001-SE	螺母	Nut M5	(1)
17		SM-9061080-SE	螺钉	Screw M6 L=10	(1)
18		SM-9050813-SE	螺钉	Screw M5x0.8 L=8	(1)
19		WP-0520656-SA	垫圈	Washer 5.2x9.5x0.6	(1)
20		WS-0510002-KN	弹性垫圈	Spring washer	(1)
21		WS-0521010-KN	弹性垫圈	Spring washer 5.2x8.2x1	(1)
22		229-31208	导线圈	Thread guide	(1)

十三、桌架零件 Table & stand components

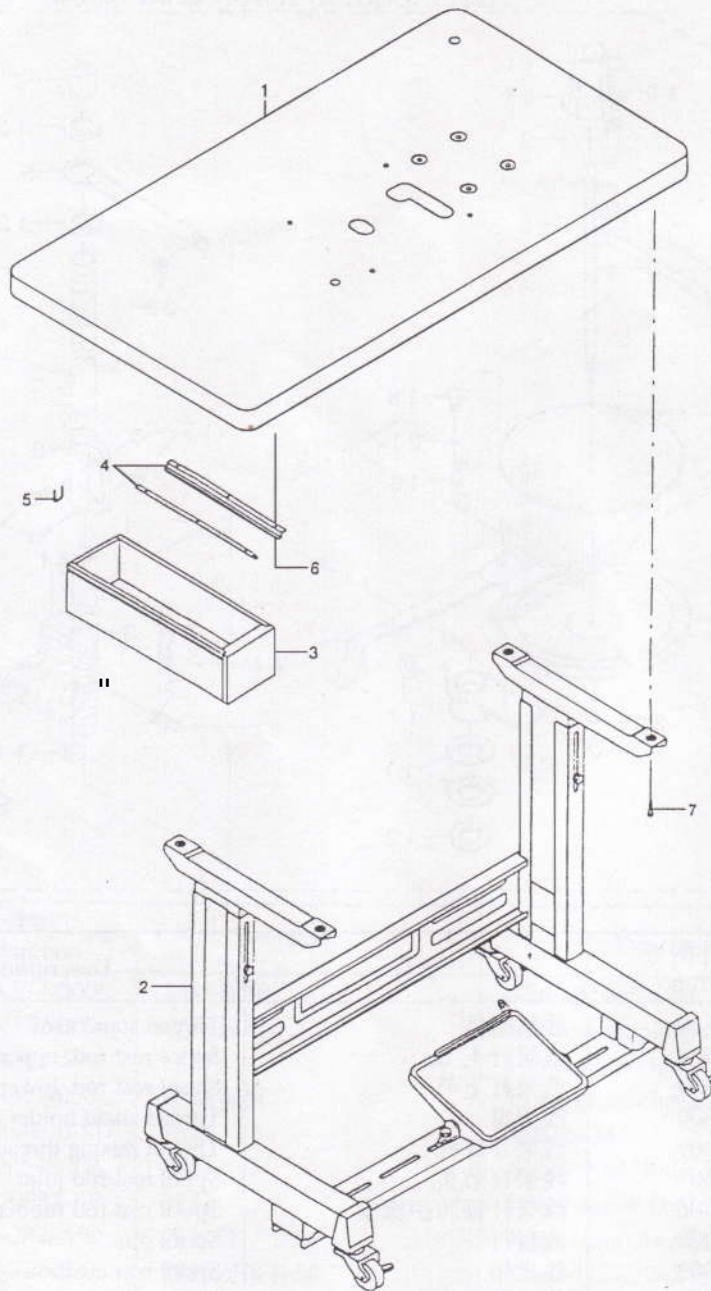

Ref.no	注解 Note	零件图号 Part.no	名称	Description	数量 Qty
1		B820t-372-A0A	电机桌	Motor table	1
2		t1t-59365	T型连接	T stand junction	1
3		III-455108	抽屉	Drawer	1
4		III-55207	抽屉支架	Drawer support	2
5		D820,4555D000	抽屉挡块	Drawer stopper	1
6		SK-33116&SE	木螺钉	Wood screw D3.1 L=16	6
7		SK-383200.5E	木螺钉	Wood screw D=4.8 L=32	4